

Einbauanleitung *Installation guide*

Frontega-VB „Vollbau“ *Wood door leaves*







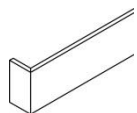
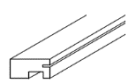
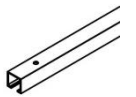

JELD-WEN
DOOR SOLUTIONS

Schiebetürsystem vor der Wand, 1 & 2 flg. mit/ohne Zarge *Sliding door front wall, 1 & 2 door leaves with or without door frame*

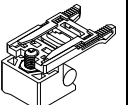
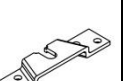
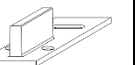
1 Lieferumfang *Fitting set*

Version: 05/2022

H-STOFF 489

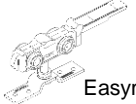
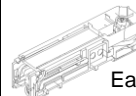
	A	B	C	D	E	F	G	H	I	J	K
 (1 – flügelig) 1-door leaf										 4 x 40 mm	
	(1x) [2 x]	(1x) [2 x]	(1x) [2 x]	(2x) [4 x]	(2x) [4 x]	(2x) [4 x]	(1x) [2 x]	(6x) [10 x]	(6x) [10 x]	(8x) [16 x]	
 [2- flügelig] 2-door leaf	L	M	N			Q		R			
			 3 x 30 mm			 Optional für beidseitiger Easymotion Dämpfung <i>Optional damping</i>	 Optional für beidseitiger Easymotion Dämpfung <i>Optional damping</i>				
			(3x) [6 x]			(2x) [4 x]	(2x) [4 x]				

Vorbemerkungen: *Preliminary note*

Die Vorgaben und Hinweise des Dokumentes „Allgemein-, Montage-, Verwendungs- Sicherheitshinweise.pdf“ sind zu berücksichtigen und einzuhalten!

The specifications and notes in the document "General, Assembly, Use, Safety Instructions.pdf" must be observed and complied with!

Benötigte Werkzeuge: *Needed tools*

Hammer *Hammer*

Schraubendreher *Screwdriver*

Messer *Knife*

Wasserwaage *Spirit level*

Säge bzw. Stichsäge *Saw*

Hobel *Plane*

Gabelschlüssel 6/ 13 *Open end spanner*

Bohrmaschine *Power drill*

Bohrer *Drill*

Inbusschlüssel 3, 4 und 5mm *Allen key*

Silikonkartuschenpresse *Silicon injectionstech*

Stecheisen *Crowbar*

Maßzusammenhänge: *Dimensions*

Türblattbreite = STLB + 100mm *Door width*

Türhöhe = STLH + 20mm *Door height*

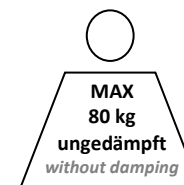
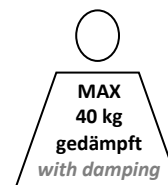

Querschnitt und Bemaßung *Cross section and dimensions*

Mit Durchgangszarge *With doorframe*

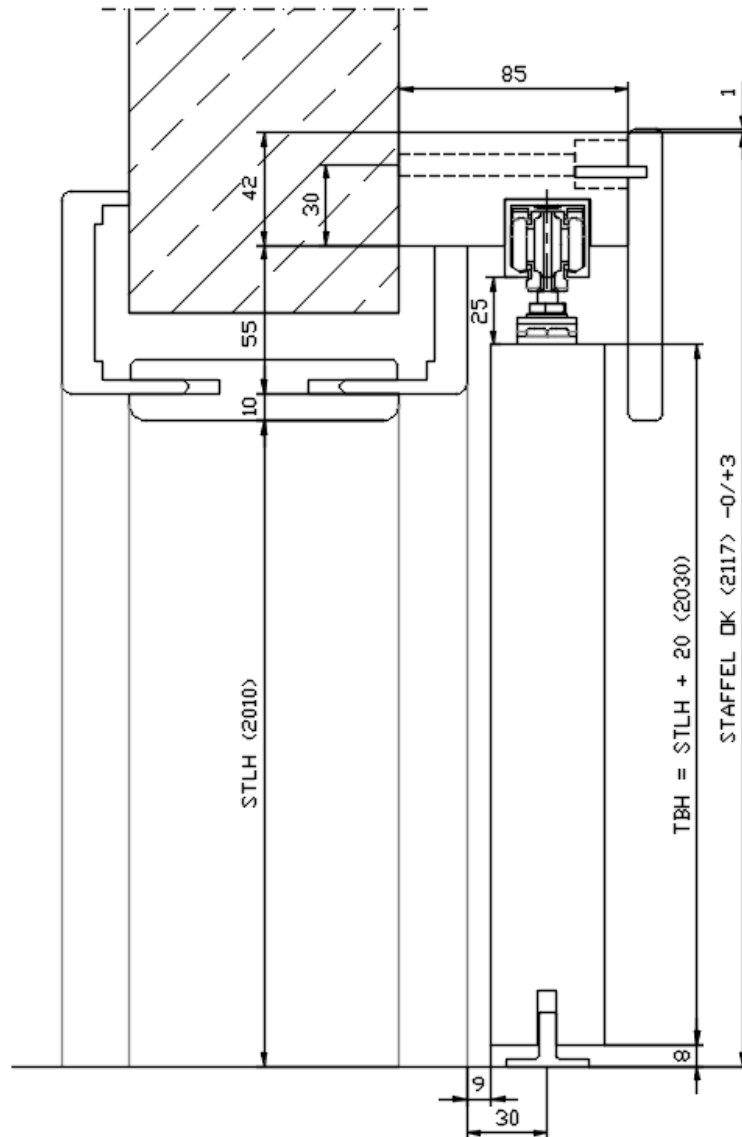

Ohne Durchgangszarge *Without doorframe*

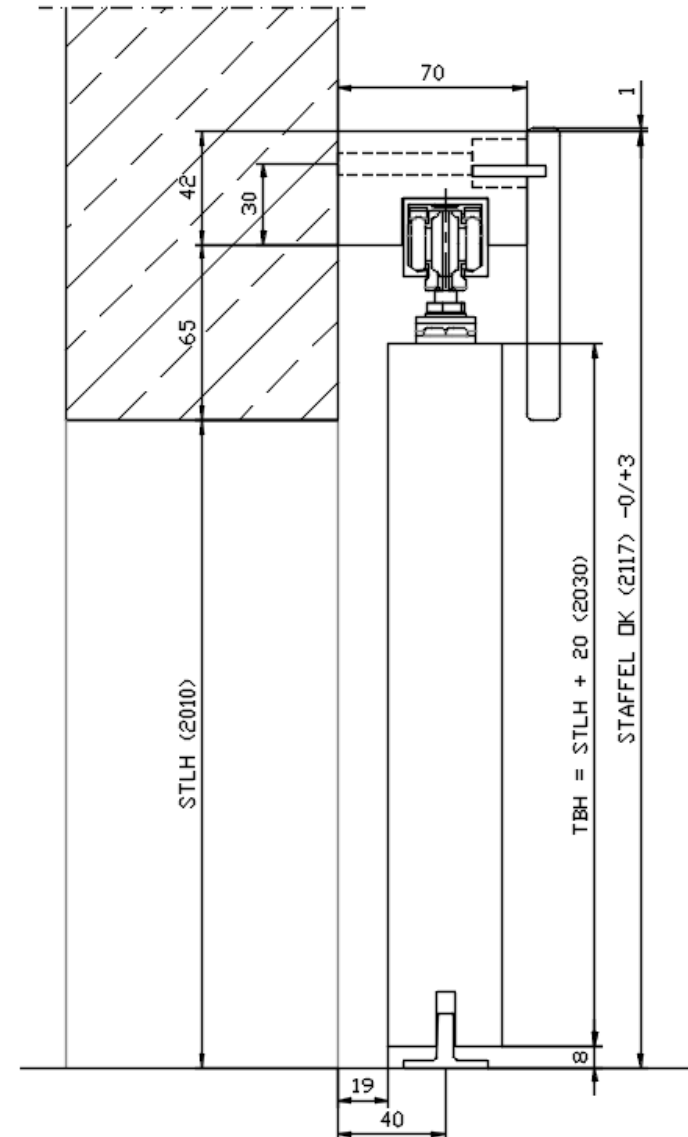

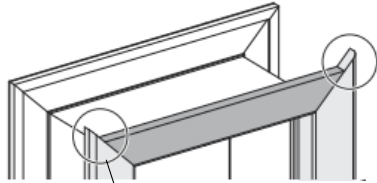
2 Staffel inkl. Laufschiene montieren / Verkleidungsspitzen kürzen *Fitted wooden profile incl. running rail / the tips of panelling trimmed*

Die horizontale Zargenverkleidung für die Schiebetürseite ist werkseitig gekürzt. Die Spitzen der vertikalen Zargenverkleidung müssen bauseits gekürzt werden. Montage der Zarge laut Zargeneinbauanleitung!

The horizontal frame panelling for the sliding door side is shortened at factory. The tips of the vertical frame panelling must be trimmed on site. Install the frame according to the frame installation instructions!

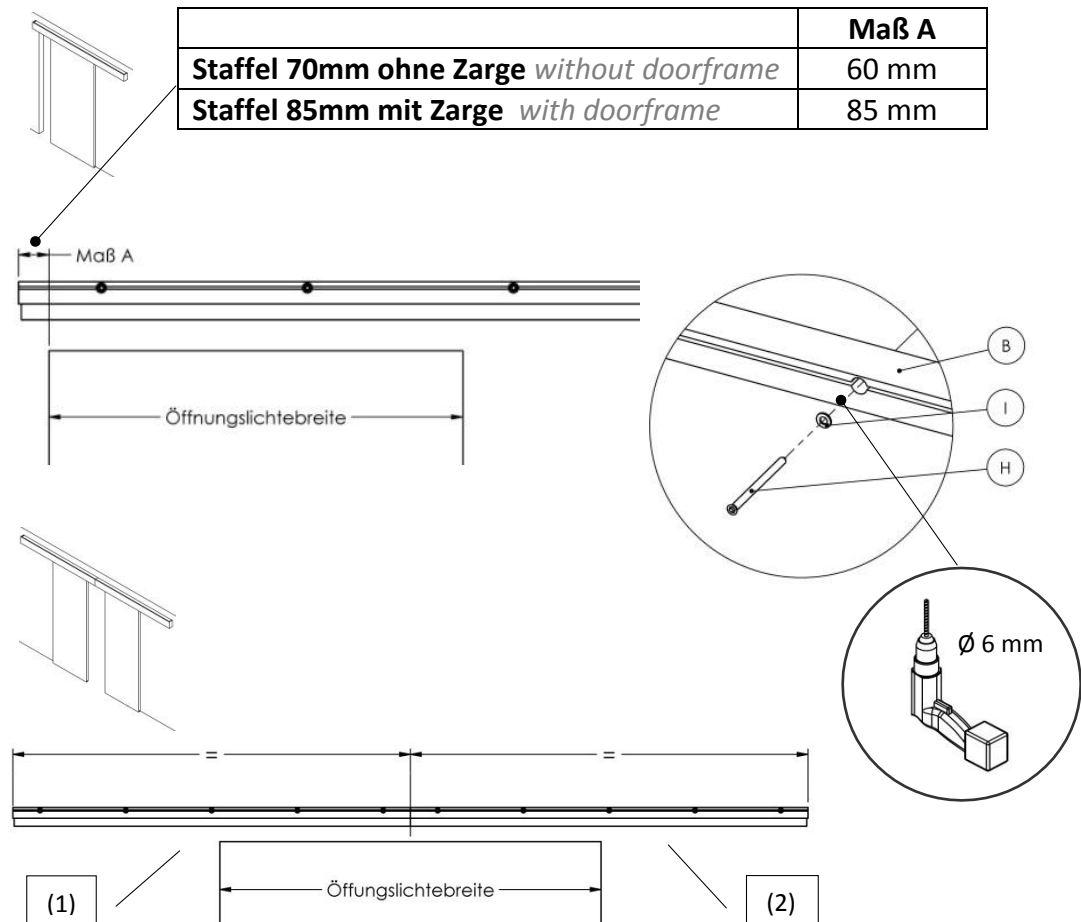
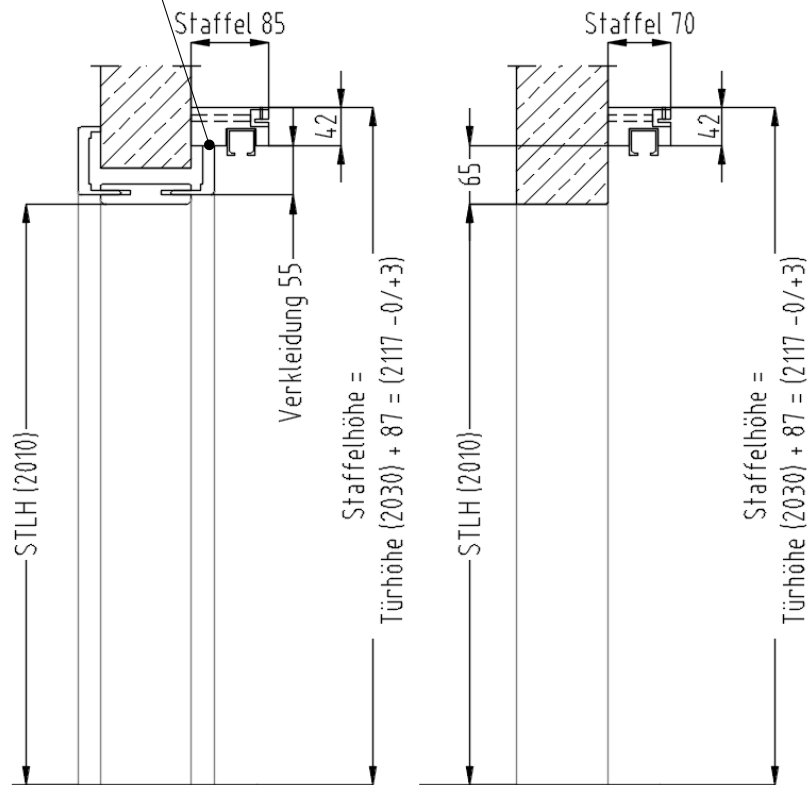

3 Beschläge in Laufschiene montieren *Mount fittings in running rail*

Ohne Dämpfung *without damping*

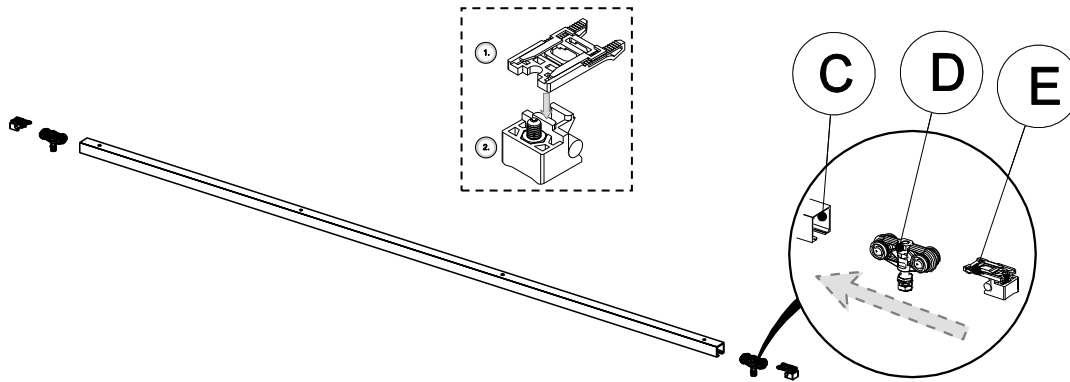

Mit Dämpfung Easymotion *with damping Easymotion*

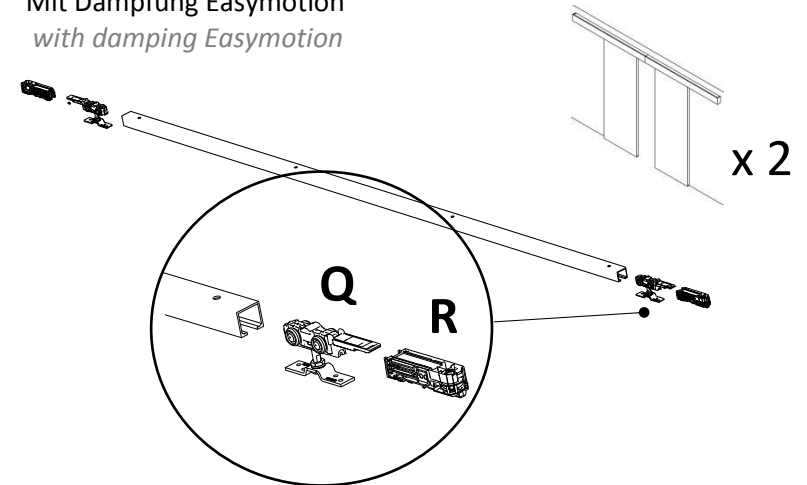

4 Türblattmontage *Door leaf assembly*

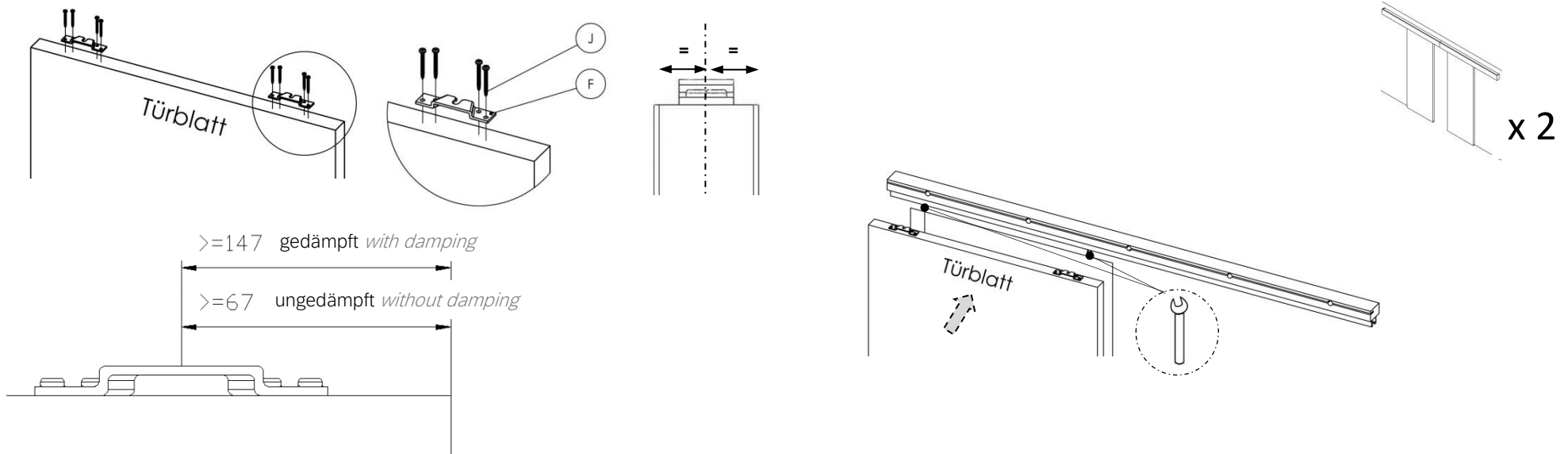

5 Bodenführung montieren *Floor guide assembly*

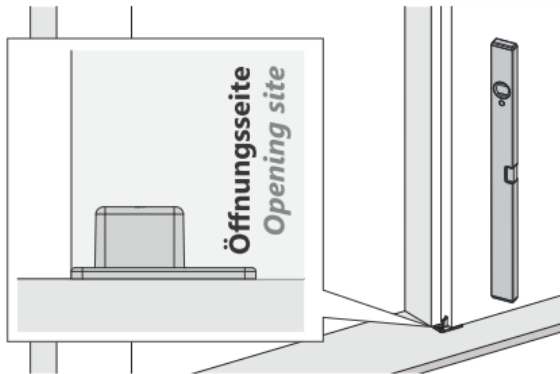

Montagehinweis: *mounting instructions*

- Türblatt ins Lot richten und Bodenführung danach ausrichten.
- Das Befestigungsmaterial muss an die örtlichen Gegebenheiten angepasst werden!
Im Fall einer Fußbodenheizung, kann die Bodenführung geklebt werden.
- *Align the door leaf perpendicularly and align the floor guide accordingly*
- *The fixing material must be adapted to the local conditions!*
In the case of an underfloor heating, the floor guide can be glued.

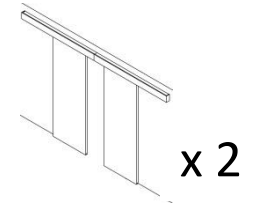

6 Holzblende montieren und sichern *Mount and secure wooden panel*

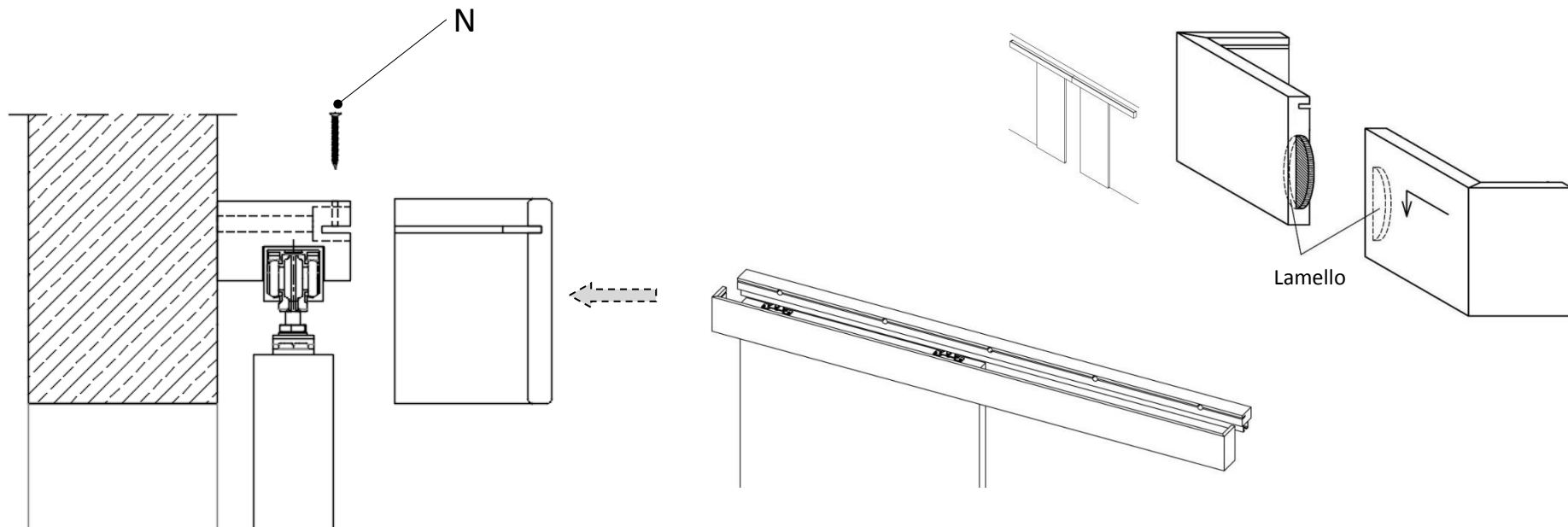

7 Feststeller / Dämpfer einstellen *Adjusting the stopper and damper*

Ohne Dämpfung *without damping*

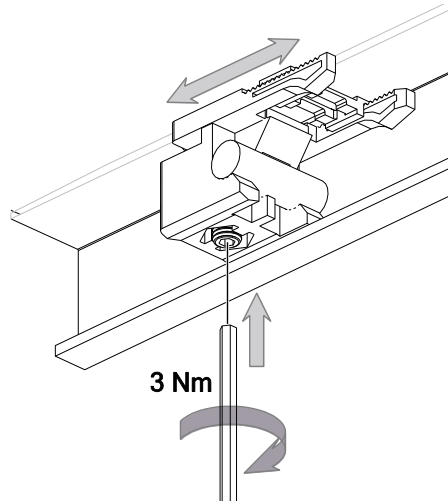

Position einstellen
Adjusting the stopper

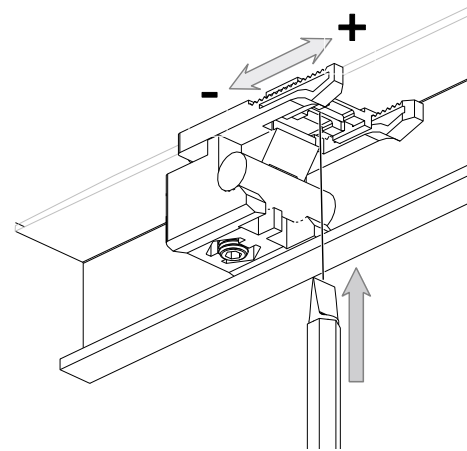

Feststellkraft einstellen
Adjusting the locking force

Mit Dämpfung Easymotion
with damping Easymotion

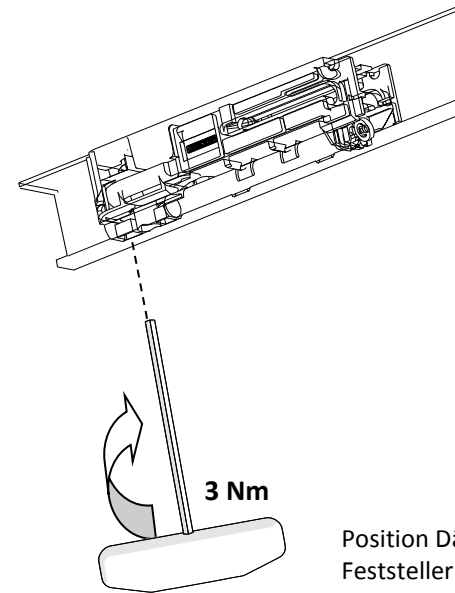

Position Dämpfer und
Feststeller einstellen.
*Adjust the position of the
dampers and stopper.*

